

BLANCO

GUIDE TO INSTALLATION

SteamOven

BOSS382X

Dear Customer,

Thank you for buying a BLANCO Steam Oven.

Before we continue telling you about this oven, we cordially invite you to become part of the Blanco family by subscribing online. Please visit our website where you can easily subscribe and request such things as 'invitations to future cooking classes' and gourmet recipes. Go to www.blanco-australia.com.au and fill in the subscription details.

You will find that the clean lines and modern look of your BLANCO Steam Oven blends in perfectly with your kitchen décor. It is easy to use and performs to a high standard.

Blanco also makes a range of products that will enhance your kitchen such as cooktops, rangehoods, dishwashers and microwaves, sinks and taps. There are models to complement your new BLANCO Steam Oven.

Of course, we make every effort to ensure that our products meet all your requirements, and our Customer Relations department is at your disposal, to answer all your questions and to listen to all your suggestions.

Please complete the warranty card and keep your receipt as proof of purchase. Retain all documents relating to the purchase of this product.

Blanco is committed to providing increasingly efficient products, that are easy to use, and are not just beautiful, smart

BLANCO

1 / NOTICES TO THE USER

- Steaming04
- Safety instructions06
- Packaging09

2 / INSTALLING YOUR APPLIANCE

- Choosing the location10
- Electrical connection12

3 / DESCRIPTION OF YOUR APPLIANCE

- Operation14
- Presentation of your oven14
- Accessories15
- Control panel and programmer16

4 / USING YOUR APPLIANCE

- Setting and adjusting the time17
- Locking the control panel18
- Immediate steaming19
- Defrosting20
- Advice21
- Water management22
- Programmed cooking23
- Timer function24

5 / DESCRIPTION OF FUNCTIONS AND COOKING TABLE

- Cooking table25

6 / MAINTAINING AND CLEANING YOUR APPLIANCE

- Cleaning the outer surfaces27
- Cleaning the inside of the oven27
- Cleaning the water supply pipe27
- Cleaning the steam generator27
- Cleaning the discharge spout27

7 / TROUBLESHOOTING

- Changing the bulb29

8 / AFTER-SALES SERVICE

- Maintenance and repairs30

• STEAMING

General

Steaming has many advantages if used correctly. Healthy and natural, steaming helps food to retain its taste. A light or herby sauce adds that little touch that makes all the difference.

It does not give off any smells. There is no need to flavour the cooking water with herbs or spices. However, fish can be flavoured by cooking it on a bed of seaweed or poultry on a bed of rosemary or tarragon.

Meat, fish and vegetables can be cooked together.

Pasta, rice and purées can be gently heated without any risk of sticking or drying.

Making cream desserts, custard tarts, rice puddings, etc. is easy... if you cover them with foil the water from the condensation will not wet them.

There is no need to add salt before cooking, or even any cooking water.

To give meat a better appearance, brown it first all over in hot butter in the frying pan.

Compared with boiling, steaming only offers advantages:

It is fast: cooking starts immediately while the cooking time for food in a pan of water only starts from when the water begins to boil.

It is healthy: the vitamins (those known as hydrosoluble) and mineral salts are well preserved because they barely dissolve in the condensed water that covers the food.

Furthermore, no fat is used to aid cooking.

Steaming preserves the taste of the food. It does not add any flavour or grilled or fried taste and does not take any flavour away because there is no dilution in the water.

Steaming does not allow tastes or smells to mix, so don't hesitate to save time and money by cooking fish and a dessert side by side but without touching, for example.

Steaming is also suitable for blanching, reheating or even keeping warm, especially sauces.

First of all, put poultry, veal, pork, etc. in the frying pan with very little fat to give them an appetising golden appearance. Then finish cooking them by steaming.

Cut into small pieces, food cooks more quickly and evenly than if it is cooked whole.

IMPORTANT SAFETY INSTRUCTIONS - READ CAREFULLY AND RETAIN FOR FUTURE USE.



Important

When you receive the appliance, unpack it or have it unpacked immediately. Give it an overall inspection. Make note of any concerns or reservations on the delivery slip and make sure to keep a copy of this form. Keep this user guide with your appliance. If the appliance is ever sold or transferred to another person, ensure that the new owner receives the user guide. Please become familiar with these recommendations before installing and using your oven. They were written for your safety and the safety of others.

- **WARNING:**

- The Appliance is not intended for use by persons (including Children) with reduced physical, sensory or mental capabilities, or lack of experience and knowledge, unless they have been given supervised instruction concerning use of the appliance by a responsible person for their safety.

- Children must be supervised to prevent them from playing with the appliance.

- **WARNING:**

- The appliance and the accessible parts of it will become hot during use. **CARE SHOULD BE TAKEN TO AVOID HEATING ELEMENTS INSIDE THE STEAM OVEN.**

- **Use**

- Your appliance is intended for standard household use. Do not use it for commercial or industrial purposes or for any other purpose than that for which it was designed.

- This oven does not contain any asbestos-based components.

- Do not modify or attempt to modify any of the characteristics of this appliance. This would be dangerous to your safety.

- Never pull your appliance by the door handle.

- When placing dishes inside or removing them from the oven, do not place your hands close to the upper heating elements and use

heat-protective kitchen gloves.

- Do not place heavy weights on the open oven door, and make sure that children are able neither to climb nor sit on it.
- Do not use your oven as a larder or to store any items after use.
- After using your oven, make sure that all the controls are in their stop position.

- Maintenance and cleaning

- Do not use a steam cleaner.
- For any cleaning operation inside the oven cavity, the oven must be switched off.
- Do not use abrasive cleaning products or hard metal scrapers for cleaning the oven's glass door, as they could scratch the surface and cause the glass to shatter.
- To clean both the electronic programmer window and the oven door, use to a soft cloth.



Warning:

Make sure the appliance is disconnected from the power before replacing the lamp in order to avoid the risk of electric shock. Change the lamp only when the appliance has cooled down. To unscrew the view port and the light, use a rubber glove, which will make disassembly easier.



Warning :

Installation should only be performed by qualified installers and technicians.



Warning :

You **MUST** fill the water tank to the maximum level before cooking. Fit the tank in its housing by pressing it in **AS FAR AS IT WILL GO** until you feel it **RUN OVER A NOTCH**.



Warning :

The appliance becomes hot during cooking. Hot steam escapes when you open the door of the appliance. Keep children away.



Warning :

The electrical plug must remain accessible after installation. It must be possible to disconnect the appliance from the power supply, either using a plug or by fitting a switch on the fixed wiring system in accordance with installation rules. If the power cable is damaged, it should be replaced by the manufacturer, its after-sales service department or by a similarly qualified person in order to avoid danger.

• PACKAGING



– This appliance's packing materials are recyclable. Recycle them by depositing them in local authority containers provided for this purpose.

– Your appliance also contains many recyclable materials. It is therefore marked with this logo to indicate that used appliances must not be mixed with other waste. Contact your local council or your retailer to find out the drop-off points for used appliances that are nearest to your home.

• CHOICE OF LOCATION

The above diagrams show the dimensions of a cabinet that will be able to hold your oven.

This appliance may be installed either under a worktop or in a cabinet column, as indicated on the installation diagram. Your oven has optimised air circulation that allows it to achieve remarkable cooking and cleaning results if the following guidelines are followed:

- Centre the oven in the unit so as to ensure a minimum distance of 10 mm between the appliance and the surrounding unit.

The material of the unit supporting the appliance must be heat-resistant (or covered with a heat-resistant material). For greater stability, attach the oven to the unit with 2 screws through the holes provided on the side panels (fig.1).

• BUILD-IN

- 1) Drill a hole \varnothing 2 mm in the cabinet panel to avoid splitting the wood.
- 2) Attach the oven with the 2 screws.



Tip:

To be certain that you have properly installed your appliance, do not hesitate to call on a household appliance specialist.

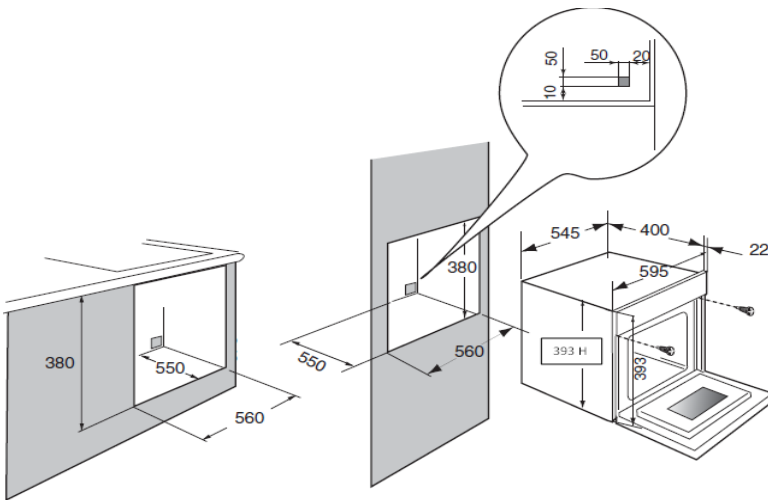

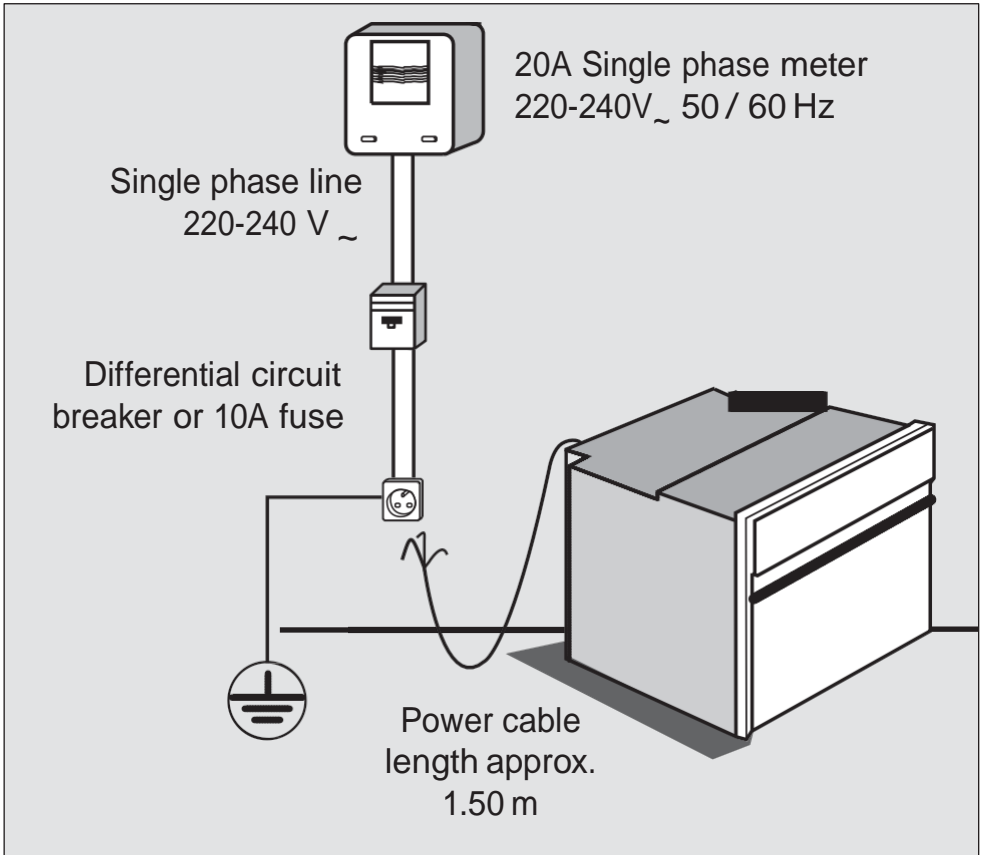

• ELECTRICAL CONNECTION

The appliance must be fitted correctly to guarantee electrical safety. During fitting and maintenance operations, the appliance must be unplugged from the electrical grid. Fuses must be switched off or removed.

The electrical connections are made before the appliance is installed in its housing.

Ensure that:

- the electrical installation has sufficient voltage,
- the electrical wires are in good condition,
- the diameter of the wires complies with the installation requirements.

Your oven must be connected with a (standard) power cable

with 3 conductors of 1.5mm² (1 live + 1 neutral + earth) which must be connected to a 220-240V_~ single-phase grid by means of a 1 live + 1 neutral + earth IEC 60083 standard power socket or via an all-poles cut-off device in compliance with the installation rules.



Warning :

If the electrical installation in your residence requires any changes in order to hook up your appliance, contact a professional electrician.

If the oven malfunctions in any way, unplug the appliance or remove the fuse corresponding to the sector where the oven is hooked up.

The safety wire (green-yellow) is connected to the appliance's  terminal and must be connected to the earth terminal of the electrical set-up.

You must enable the appliance to be disconnected from the supply network after installation.

Disconnection can be enabled by ensuring that there is an accessible power plug or by incorporating a switch into the fixed wiring in compliance with the installation rules.

The fuse in your set-up must be 10 amperes.

If the power cable is damaged, it should be replaced by the manufacturer, its after-sales service department or a similarly qualified person to avoid danger.

• OPERATION

The water contained in the tank reaches the inside of the oven via a pipe. This water is transformed into steam through contact with a hot surface placed at the bottom of the oven:

This is the steam generator.

It is not necessary to add water to the dish being cooked. To guarantee AUTHENTIC STEAMING, your oven comes with a set of dishes specially designed for perfect steaming.

Warning

You **MUST** fill the water tank to the maximum level before cooking. Fit the tank in its housing by pressing it in AS FAR AS IT WILL GO until you feel it **RUN OVER A NOTCH**.

Warning

The appliance becomes hot during cooking. Hot steam escapes when you open the door of the appliance. Keep children away.

• PRESENTATION OF YOUR OVEN

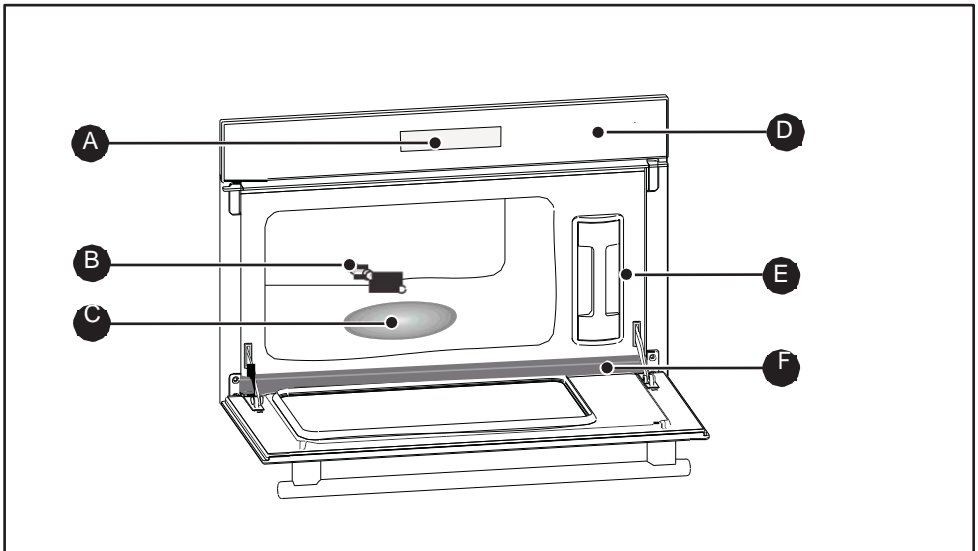

A Indicator

B Water feed pipe

C Steam generator

D Control panel

E Water tank

F Discharge spout

• ACCESSORIES

• Perforated Tray X2 (fig.1)

Stainless steel dish perforated to avoid contact between the food and the condensation water.

• Solid drip tray X2 (fig.2)

Stainless steel dish for recovering the water from condensation.

• Grill (fig.3)

Stainless steel removable support rack: must be placed in the oven.

• High level grid X1 (fig. 4)

Stainless steel support rack for the second set of cooking dishes. To use the second set of cooking dishes

- 1- Clip the High level grid onto the grill
- 2- Place the first set of cooking dishes onto the grill
- 3- Place the second set of cooking dishes onto the High level grid (fig. 5)

• Removable tank (fig.6)

Tank for supplying your oven with water independently.

Capacity of approx. 1 litre (maximum level).

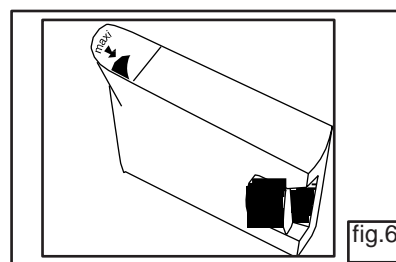
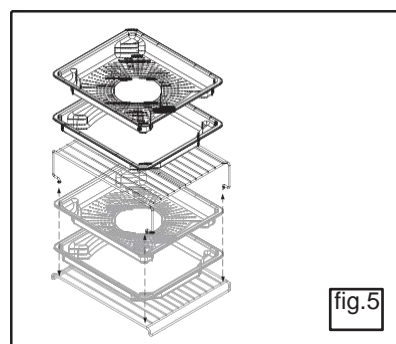
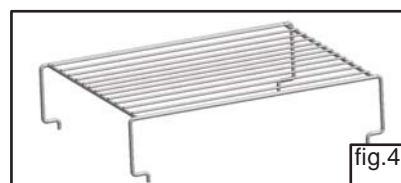
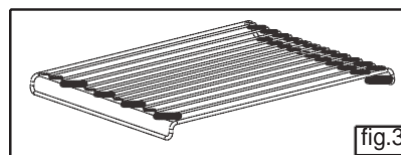
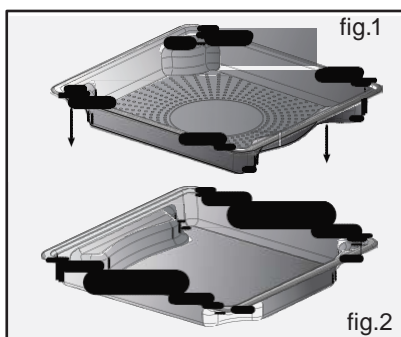

Tip

The use of slightly hard water will make it easier to maintain your oven. The dishes are dishwasher safe.



Warning

The use of demineralised water is prohibited (not suitable for consumption). The use of softened water may damage the surface of the steam generator. It is best to use bottled mineral water.

● CONTROL PANEL AND PROGRAMMER

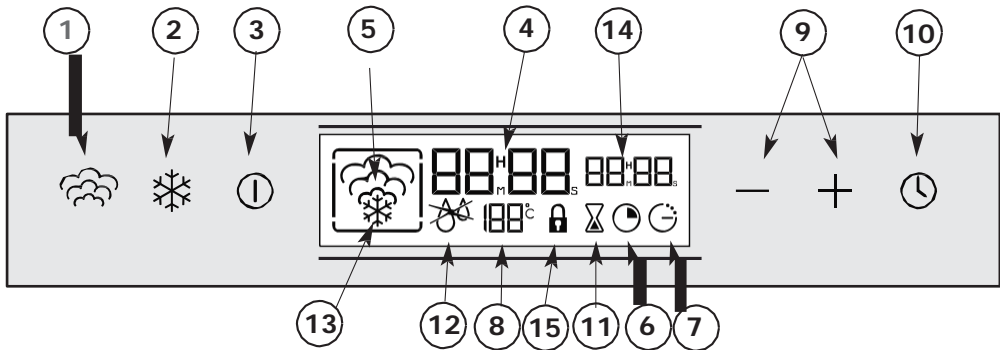

- | | |
|--|--|
| <ol style="list-style-type: none"> 1. Steam cooking control 2. Defrosting button 3. Start/Stop control 4. Time and delay display or timed period 5. Steam cooking symbol 6. Cooking time symbol 7. End of cooking time symbol | <ol style="list-style-type: none"> 8. Temperature display 9. +/- controls for timer 10. Selector button : SET 11. Autonomous timer 12. Water circuit problem signal 13. Defrosting symbol 14. Display of the cooking period or delayed start time 15. Control panel locked |
|--|--|

• SETTING AND ADJUSTING THE TIME

Setting the time

The first time the oven is turned on:
Set the time.

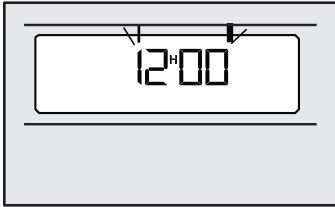

1 The display flashes on 12.00.

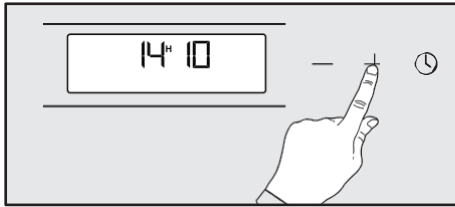

2 Use the + and - buttons to adjust the time.

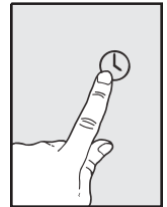

3 Validate with SET.

Changing the time

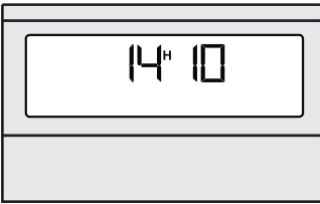

1 The time is displayed.

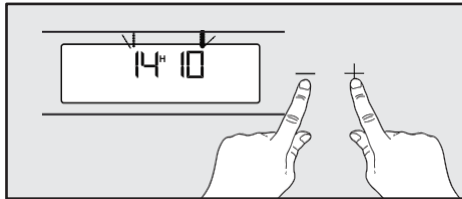

2 Press on the + and - buttons simultaneously until the time starts to flash.
Adjust the time using the + and -button.



3 Validate with SET



If the time set is not validated by the SET button, it is automatically recorded after one minute.

Reducing energy consumption

After one minute of inactivity, display brightness is reduced, in order to reduce energy.

• LOCKING THE CONTROL PANEL

The control panel can be locked. This can only be activated when you are not using timed or delayed cooking features.



1 Hold down the START/STOP button for a few seconds.

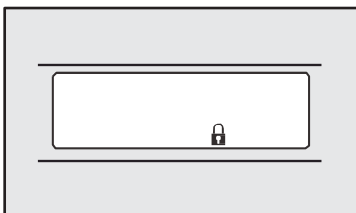

2 A beep sounds and a "padlock" appears on the screen. From this moment, no button is live.

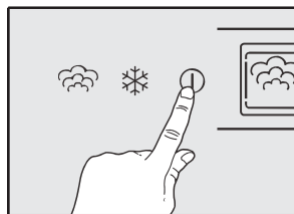

3 To unlock, hold down the START/STOP button for a few seconds. A beep sounds and the padlock disappears.

• IMMEDIATE STEAMING

Steam cooking

Steam cooking at 100°C.

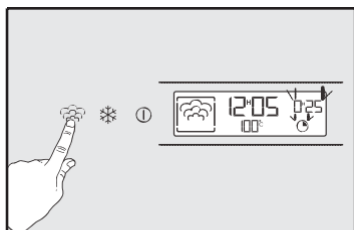

- 1** Press the button . A time of 25 minutes is suggested.

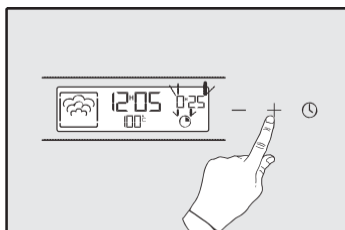

- 2** Adjust the cooking time as necessary (minimum 5 min and maximum 60 min) by pressing on + and - button



- 3** Confirm selection with the START button.

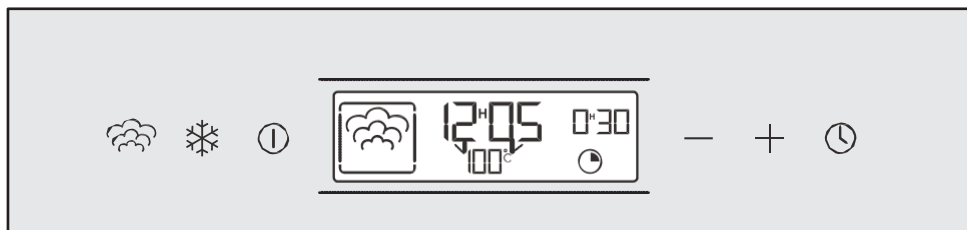

- 4** The symbol comes on. When the temperature is reached, 100° becomes constant, and a beep sounds.



In order to avoid altering the results of the cooking, avoid opening the appliance door during cooking.

● DEFROSTING

Defrosting at 60°C.

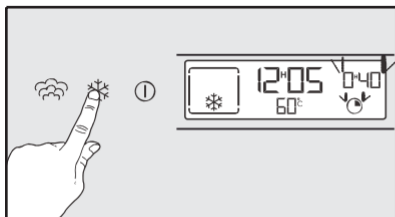

1 Press the button . A time of 40 minutes is suggested.

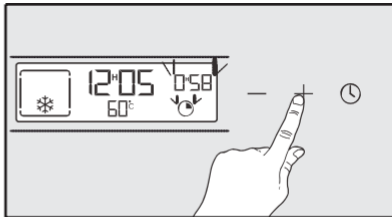

2 Adjust the cooking time as necessary (minimum 5 min and maximum 60 min) by pressing on + and - button.



3 Confirm selection with the START button.

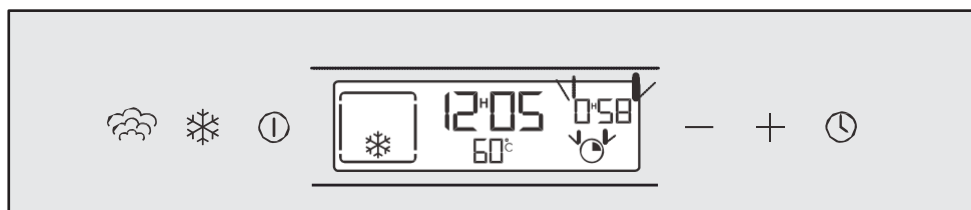

4 The symbol comes on. When the temperature is reached, 60° becomes constant, and a beep sounds.

Modifying the cooking time

During cooking, you can modify the cooking time by using the + and - buttons.

Stopping the appliance during cooking

You can stop the cooking at all times by pressing on START/STOP (hold the button down for about 1 second).

If the steam production has not yet started (about 1 minute), the oven will stop immediately and the time setting will disappear.

If the steam production has already started, the time passes to 3 minutes and during this period, the steam evacuates before you open the oven.

At the end of cooking

0m00s displays. The display animation stops. Beeps are heard for a 3 minute period.

To stop the beeps, press on STOP and open the door.

You MUST empty the tank after each use



In order to make sure the oven is reliable, the fan continues to operate for a certain period after the end of cooking.

● ADVICE

Freeze small portions; defrosting will be faster, more homogenous and quality will be preserved. When semi-defrosted, you can turn over the food items or spread them out (for example vegetables patties). Protect pastries with a cling wrap or keep the original packaging. Wipe fish and sausages before grilling: humidity stops them from becoming golden brown. For large pieces (roasts, etc.) proceed in steps by turning the piece over several times and adjust the time accordingly.

VEGETABLES	Patties (spinach, etc.)	placed on dish	25 min
	In blocks	placed on dish	40/45 min
	Trout (whole)	placed on dish	30 min
FISH	Salmon steak	placed on dish, turned over half way through	25 min
	Filets (protected by a cling wrap)	placed on dish	15/20 min depending on thickness
	Prawns	placed on dish	10/12 min
MEATS	Chicken thighs	placed on dish, turned over half way through	40/45 min
	Poultry breast (protected by a film)		25 min
	Sausages	placed on dish	25 min
	Chops (pork, veal, etc.)	placed on dish, protected by a cling wrap, placed on the grill	25/30 min
	Liver cubes (for skewers)	to be separated half way through	55/60 min
FRUIT	Mixed berries	placed on dish	15 min
	Stewed fruit (apple, etc.)	protected by a cling wrap	35/40 min
PASTRIES	Doughnuts	kept in packaging, placed on the grill	15 min
	Chocolate croissants	kept in packaging, placed on the grill	15 min

● REHEATING

You can reheat a cooked dish in your steam oven. The dish will not dry out, will not become overcooked and will not splatter or stick. Adjust steam sequence at 100°C, place the dish or plate on the grill, protect with aluminium foil or cling wrap to avoid drops of water accumulating and heat for 20 to 25 minutes depending on the dish and your preferences.

Examples:

A plate of sauerkraut: 20 min

A bowl of soup (300 ml): 20/25 min

• WATER MANAGEMENT

In case of problems related to the water circuit during cooking, the 'no water' symbol appears and a beep sounds. This fault is specifically related to:

- an empty tank,
- a wrongly-fitted tank.

After checking these two points, the cooking will recommence automatically after the door is closed.



● PROGRAMMED COOKING

Steam cooking at 100°C.

You can program the cooking time so that your dish is ready at a time of your choice.

For example:

It is 10 o'clock, and you have to go out, your dish should be ready at 12 o'clock and it will take 20 minutes to cook.

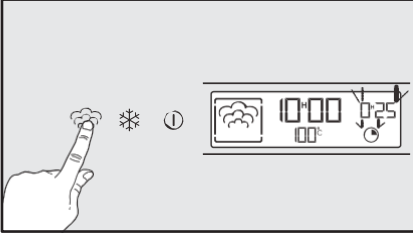

- 1** Press the button .
A time of 25 minutes is suggested.

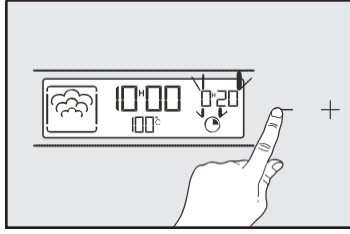

- 2** Adjust the cooking time as necessary (minimum 5 min and maximum 60min) by pressing on + and - button.

For example : 20 min.

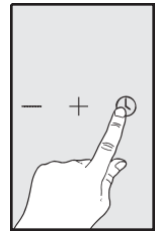

- 3** Confirm selection with the SET button.

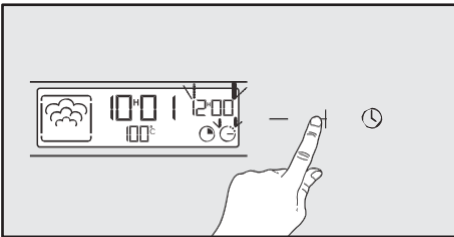

- 4** The time and the end of cooking time symbol display and flash. The adjustment of the end of cooking time is now possible:
Press the + or - buttons
For example : 12h00

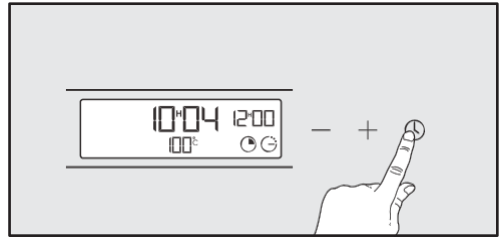

- 5** Confirm selection with the SET button.
The time and the end of cooking time become constant.
The symbol for the length of cooking time displays.

 If the programming is not validated by touching SET, the recording of the program is cancelled, the time display disappears and the time is displayed again.

Modification of cooking time and the end of cooking time

You can consult or modify the length of cooking time and the end of cooking time, at all times.
To cancel the programming, press START/STOP.

• TIMER FUNCTION

Your oven is fitted with an electronic timer that is independent of the operation of the oven, and allows time to be counted down.

 This function is independent of your oven. It can not order the end of automatic cooking.

However, this function can be used even during operation of the oven. In this case, the display of the timer is given priority over the display of the time.

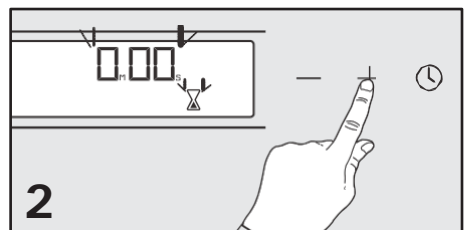
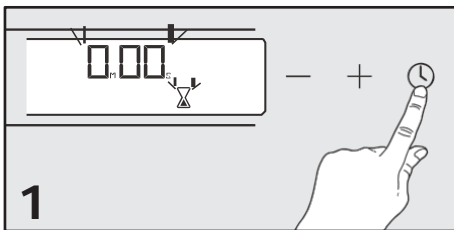

1 Hold the SET button down for a few seconds. 00m00s and the timer symbol flash.

2 Adjust to the period required (maximum 59 minutes and 50 seconds) using the + and - buttons. After a few seconds, the timer counts down the time.

Once the time has run out, beeps will sound every few seconds. 0m00s displays and flashes.

• MODIFYING AND STOPPING THE TIMER

The beeps can be stopped by holding down SET or START.

Once the countdown has started, you can modify the time remaining by holding down SET then pressing the + or - buttons.

To cancel the timer, hold SET down for a few seconds, then return the time to 0m00s.

	FOOD Any quantity	TIME	°C	PREPARATION	COMMENTS
VEGETABLES	Artichokes (small)	40 to 45 min	100	placed upside down on the plate	<ul style="list-style-type: none"> • These times depend on the nature, thickness and freshness of the vegetables. Follow the instructions shown in the "preparation" column. • The cooking time is the same irrespective of the quantity to be cooked. E.g.:1 or 4 artichokes –same cooking time. • To control the level of cooking, pierce the thickest part of the vegetable, if it is cooked there will be no resistance.
	Asparagus	35 to 40 min.	100	Reduce time for tips only	
	Broccoli	18 min.	100	florets thinly	
	Carrots	20 to 22 min.	100	sliced thinly	
	Celeriac	25 to 30 min.	100	cut diced	
	Pumpkin	15 to 20 min.	100	thinly sliced	
	Mushrooms	15 min.	100	Brussels sprouts Cauliflower florets	
	Cabbage family	30 to 35 min. 22 min. 30 to 35 min.	100	Cabbage shredded sliced	
	Courgettes	10 to 15 min.	100	(fresh) stir during cooking (frozen) " "	
	Crosnes	20 min.	100		
	Spinach	20 min. 35 min	100		
	Chicory	30 min.	100	trunk removed and cut in 2 lengthwise cut in 2	
	Fennel	22 min.	100		
	Green beans	30 to 35 min.	100	diced	
	Turnip	15 to 20 min.	100	/	
	Peas fresh	20 to 25 min.	100	cut in 2	
Leeks	25 min.	100	sliced		
Potatoes	25 min. 40 to 45 min.	100	whole		
SHELLFISH	Coquilles St Jacques	10 to 12 min.	90	w/ flavourings	<ul style="list-style-type: none"> • Lay the shellfish on the mesh of the glass dish, add aromatic herbs. • Lay crabs, etc. on a bed of algae.
	Mussels/ Winkles	20 to 25 min.	95	w/ flavourings	
	Crab/ Crayfish	25 min.	95	/	
	Lobster Scampi	30 to 35 min. 12 to 15 min.	95 90	depends on weight /	
FRUIT	Apples/ peaches/pears	10 to 15 min.	90	whole, peeled	<ul style="list-style-type: none"> • Time depends on ripeness.
	Stewed	25 min.	95	fruit sliced in ramekins	
	Creamed	10 min.	90		

FOOD Any quantity		TIME	°C	PREPARATION	COMMENTS
FISH	Pike	25 to 30 min	85	whole (1 kg)	<ul style="list-style-type: none"> • *Steaks: Round pieces of fish 2 to 3 cm thick (180/200g) per person. • Buy the freshest produce. • Place whole fish on the dish or on a bed of bayleaves, fennel or another aromati herb. • At the end of cooking, remove the skin, which will come away very easily.
	Cod/Hake	13 to 15 min.	85	steaks (180 g)*	
	Bream	20 to 25 min.	85	whole (1 kg)	
	Haddock	15 min.	75	fillets	
	Herring	20 min.	85	whole (200 g)	
	Pollock	15 to 20 min.	85	steaks (180 g)	
	(black and yellow)				
	Monkfish	15 min.	80	depends on thickness	
	Mackerel	20 min.	85	whole (250 g) fillets	
	Whiting	15 min.	75		
	Skate	25 to 30 min.	80	whole (200 g) fillets	
	Red mullet	15 min.	80	6 large pieces (6 to 10 cm long) steaks	
	Mullet/Sole	10 min.	75	(180/200 g) steaks	
	Dogfish	20 min.	85	(180/200 g)	
	Salmon	15 to 20 min.	85	whole (200 g) 13 to 15 min.	
Tuna	20 to 25 min.	100			
Trout whole (1kg)	20 to 25 min.	100			
MEAT	Beef	15 to 30 min.	100	Roast 800 g : 55 to 60 min.	<ul style="list-style-type: none"> •Then brown using another dish.
	Pork (medallions)	25 min.	100	Chicken legs: 35 to 40 min.	
	Poultry (white)	20 to 25 min.	100		
	(Paupiettes)	25 min.	95	Roast turkey: 50-60 min.	
	Sausages	20 min.	90	Morteau sausage 400 g	
Puddings	10 to 15 min.	90			
EGGS	Use very fresh eggs stored at room temperature.	7 min.	100	<u>Boiled:</u> placed directly on grill. <u>Soft:</u> placed directly on grill. <u>Hard</u> <u>Poached:</u> break onto an individual plate, place on grill and cover with cling film. <u>Baked:</u> see detailed recipes.	
		8 min.	100		
		10 to 12 min.	100		
		5 to 6 min.	100		
			90		
RICE, PASTA	Place directly in a dish, cover with water or milk. Steam is not enough to saturate these foodstuffs that swell. Place a sheet of foil over the dish to avoid drops of water falling down.				
	Rice pudding	30 min.	100	100 g washed rice - 20 cl milk - 2 dessertspoons sugar 200 g (1/4 litre water)	<ul style="list-style-type: none"> • Fluff up with a fork at the end of cooking.
	Semolina	20 min.	100		

● CLEANING THE OUTER SURFACE

To clean the window of the electronic programmer and the oven door, use a soft cloth. Do not use abrasive products or hard metallic scourers to clean the glass door as this could scratch the surface and cause the glass to break.

● CLEANING THE INSIDE OF THE OVEN (AFTER EACH USE)

Rub the inside of the oven with a dry cloth after the steam generator has cooled or leave the inside of the oven to dry with the door slightly open.

● CLEANING THE WATER SUPPLY PIPE (ONCE A MONTH)

Remove the water supply pipe by unscrewing it. Remove any lime scale deposit that there may be inside the pipe (using a fine, sharp object such as a skewer or a knitting needle).

● CLEANING THE STEAM GENERATOR (ONCE A MONTH)

Pour 2 tablespoons of white vinegar into the generator. Leave to act for a few minutes, then clean and rinse with water.

Do not use a sponge or abrasive powders or kettle descaler.

● CLEANING THE DISCHARGE SPOUT

Remove the discharge spout by pulling it upwards, wipe it and put it back in place using the three notches provided for this purpose.



Warning

Do not use a steam cleaning appliance.

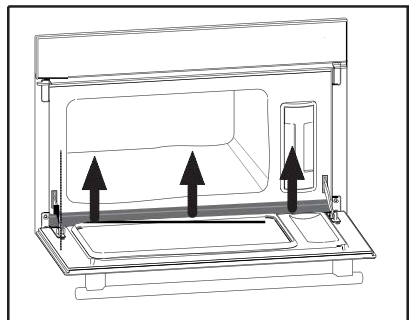

You have a question about whether or not your oven is working properly. This does not necessarily mean that there is a breakdown. In any case, check the following points:

YOU NOTICE THAT...	POSSIBLE CAUSES	WHAT TO DO?
Your display does not light up	<ul style="list-style-type: none"> - No power supply to oven. - Electronic card is not working. 	<ul style="list-style-type: none"> - Check the power supply (fuse). - Call the After-Sales Service.
Water or steam leaking through the door during cooking.	<ul style="list-style-type: none"> - The door is not closed properly. - The door seal is faulty. 	<ul style="list-style-type: none"> - Call the After-Sales Service.
The light in your oven no longer works.	<ul style="list-style-type: none"> - The light is not working. - Your oven is not plugged in or the fuse has blown. 	<ul style="list-style-type: none"> - Change the bulb. - Plug in your oven or change the fuse.



Warning

- Repairs to the appliance must only be carried out by professionals.

Repairs not carried out within the rules can be a source of danger for the user.



Tip

In any case, if your intervention is not sufficient, contact the After-Sales Service immediately.



WARNING

SAFETY: Make sure that the appliance is disconnected from the power supply before replacing the bulb to avoid any risk of electric shock.

Act when the appliance has cooled down.



TIPS

To unscrew the viewing panel and the bulb, use a rubber glove, which will make it easier to remove.

● CHANGING THE BULB

The bulb is located inside the oven on the back wall.

-Disconnect your oven from the mains before any intervention on the bulb to avoid any electric shock.

-Turn the viewing panel a quarter turn to the left.

-Unscrew the bulb in the same direction.

Bulb characteristics:

- 15 W - 220-240 V

- 300°C - Base E 14

- Change the bulb and then fit the viewing panel back into position, making sure that the seals are correctly placed.

- Reconnect your oven.

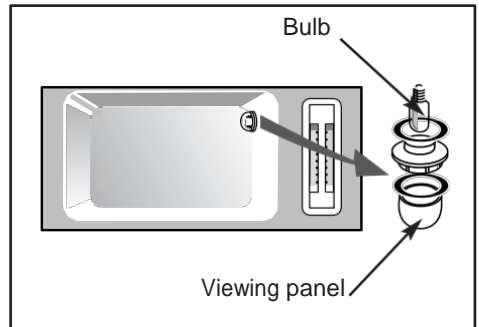

● MAINTENANCE AND REPAIRS

Any maintenance on your equipment should be undertaken by a qualified mechanic who is an authorized agent for the brand appliances. When making an appointment, state the full reference of your equipment (model, type and serial number). This information appears on the manufacturer's nameplate.

ORIGINAL PARTS

During maintenance work, ask for exclusive use of certified original spare parts.

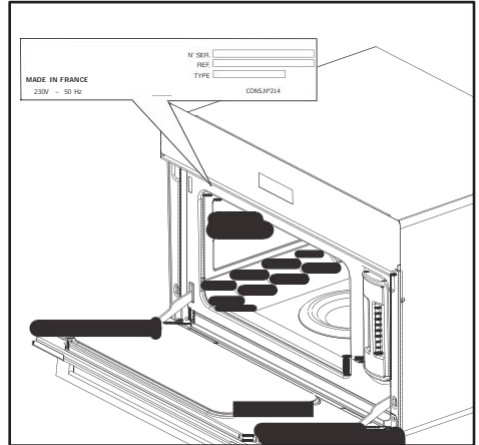

Shiro Australia
104 Vanessa St
Kingsgrove NSW 2208
1300 739 033